

200W & 300W Sign Projector

Manual 2025



Package Contents

Projector, optical lens and power cord with standard 110 Volt plug.

Description

Sign projectors are rated IP65 for outdoor use. To project an image, a high resolution glass or metal gobo is required. To order a gobo, e-mail the artwork of the desired image to sales@compliancesigns.com. Line-art or vector files are acceptable, as are pixel files (e.g. .JPEG, .PNG, .TIFF, .PDF, etc.) 300 dpi or better.

Safety Information

- For indoor or outdoor use.
- Prevent direct eye exposure to the light source as it may lead to injury or blindness.
- This projector uses a heat sink for cooling, which can heat up the projector. Please use caution when handling or touching the unit during and after operation.
- Only use power sources that comply with local electrical and building codes and have proper grounding.

Lens Specifications

- Outer diameter (OD) - 66 mm
- Inner or image diameter (ID) - up to 46 mm
- Lens thickness: Up to 3 mm

Adjusting the Image Focus

Once the lens is successfully installed, rotate the lens clockwise or counter-clockwise until the image is in focus. Once the image is in focus, turn the lock ring clockwise until the rubber gasket is slightly compressed.

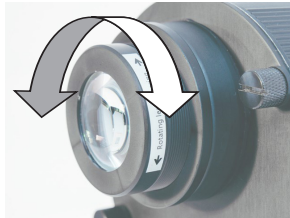

Turning Rotating Effect ON/OFF

Press the button located on the back of the projector to turn the rotator ON or OFF.



Lens Installation & Exchange

Step 1

Remove the front plate of the projector by unscrewing the thumb screws.



Step 2

Remove the metal pressure clip by squeezing together the two bent ends.

WARNING: please use caution when removing or installing the pressure clip, as it may spring or jump out unexpectedly.



Step 3

Place the gobo with image facing down (reversed) in the gobo slot.

Silver Side Down - Black Side Up



Step 4

Place the metal pressure clip on top of the lens and make sure it is pressing against the lens evenly.

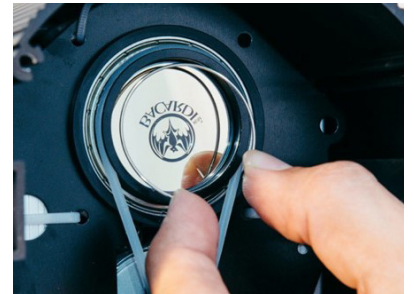

PROJECTORS MUST BE SECURED WITH A SAFETY CABLE

Specifications on Page 2 ➔

200W & 300W Sign Projector

Model	150W	200W	300W
Voltage	110 to 277 V*	110 to 277 V*	110 to 277 V*
Lamp (LED)	150 W	200 W	300 W
Rated Frequency	50/60 Hz	50/60 Hz	50/60 Hz
LED Lamp Life	30 - 40,000 Hrs	30 - 40,000 Hrs	30 - 40,000 Hrs
Color Temp. (K)	6,000 - 6,500 K	6,000 - 6,500 K	6,000 - 6,500 K
Luminous flux	13,500 lm	18,000 lm	27,000 lm
Weight	16 lbs.	16 lbs	16 lbs.

*US only - 240 V outside of US

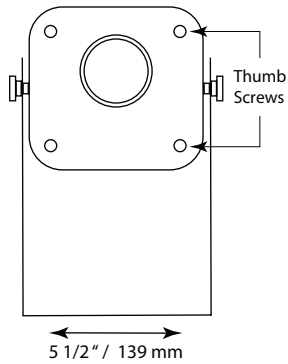

Front View

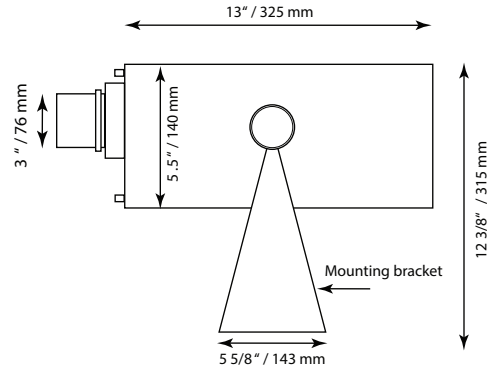

Side View

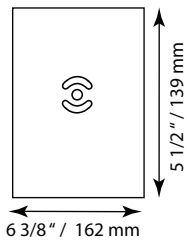

Bottom View

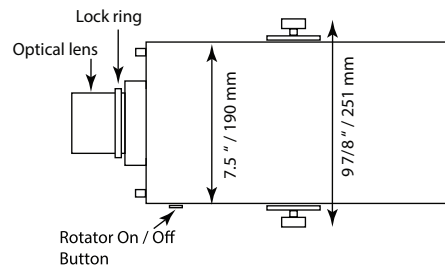

Top View

Warranty

ComplianceSigns warrants its Safety Projectors to be free from defects in materials and workmanship for a period of five (5) years from the date of original purchase ("Warranty Period"). This warranty extends only to the first end-user purchaser of the product. For details, or to obtain warranty service, please contact ComplianceSigns's customer service department at 1.800.578.1245 or sales@compliancesigns.com during normal business hours.